

STAINLESS STEEL WORK TABLES WITH BACKSLPASH



Fully Adjustable
Leg Collar

Item #: _____ Qty #: _____

Model #: _____

Project #: _____

L	24" WIDTH			30" WIDTH		
	Model	Approx. Wt.	Approx. Cu. Ft.	Model	Approx. Wt.	Approx. Cu. Ft.
24"	6068062	36 lbs.	2	—	—	—
30"	—	—	—	—	—	—
36"	6068059	44 lbs.	2	—	—	—
48"	6068054	52 lbs.	3	6068057	75 lbs.	8
60"	—	—	—	6068064	83 lbs.	10
72"	—	—	—	6068063	99 lbs.	12

FEATURES:

Top is furnished with 1 5/8" sanitary bull-nose rim on front; and square ends.

Two die formed hat channels are attached to underside of work table top to reinforce and maintain a level working surface.

Leg Collar at undershelf corner secures leg shelf to legs and is fully adjustable.

CONSTRUCTION:

All TIG welded. Exposed weld areas polished to match adjacent surface.

Top is sound deadened.

Die formed galvanized hat channels are secured to top by means of structural adhesive and weld studs.

Gussets welded to hat channels.

DETAILS and SPECIFICATIONS

ALL DIMENSIONS ARE TYPICAL

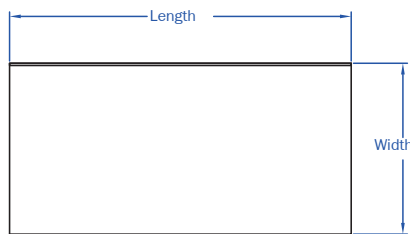

Top View

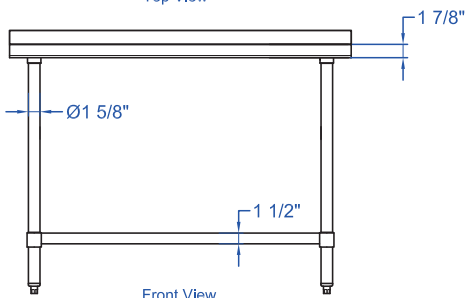

Front View

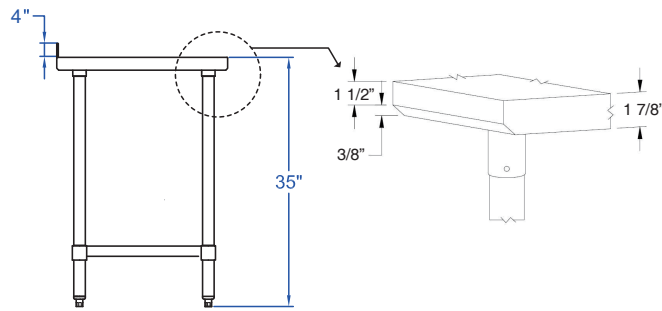

Side View

MATERIAL:

TOP: 18 Gauge Stainless Steel Type 430 Series

SHELF: 18 Gauge Galvanized Steel with Gussets

LEGS: 1 5/8" Diameter Tubular Galvanized Steel